



1532ES / 1932ES

2033ES / 2633ES

**2047ES / 2647ES /
3247ES**

OPERATOR'S MANUAL

CE Specification

This Operator's Manual
MUST BE READ AND UNDERSTOOD
prior to operating your
MEC Aerial Work Platform

TABLE OF CONTENTS

Introduction	iii
Machine Specifications	iv
SECTION 1:	
SAFETY	1-1
Safety Symbols	1-2
Safety Rules And Precautions	1-3
Fall Protection Notice	1-5
SECTION 2:	
OPERATION	2-1
Transport and Lifting Instructions	2-2
Unloading Procedures	2-3
Primary Machine Components	2-4
Operator Controls	2-5
Base Controls	2-5
Platform Controls	2-7
Prestart Inspection	2-9
Machine Start Up	2-9
Base Control Operation And Checks	2-10
Platform Control Operation And Checks	2-11
Operation	2-12
Driving And Steering	2-12
Platform Overload Sensing System	2-12
Braking	2-13
Elevating The Platform	2-13
Lowering The Platform	2-13
Extending The Roll-out Extension Deck	2-14
Charging The Batteries	2-14
Shutdown Procedure	2-15
Moving The Machine	2-15
Emergency Systems And Procedures	2-17
Emergency Lowering	2-18

SECTION 3:
MAINTENANCE 3-1

- General Maintenance Tips 3-2
- Prestart Inspection 3-4
- Frequent Inspection 3-6
- Annual Inspection 3-7
- Troubleshooting 3-9
 - What To Check If Functions Will Not Operate: 3-9
- Lubrication Diagram 3-10
- Lubrication Chart 3-11



Introduction

This Operator's Manual has been designed to provide you, the customer, with the instructions and operating procedures essential to properly and safely operate your MEC Self-Propelled Scissors for its intended purpose of positioning personnel, along with their necessary tools and materials to overhead work locations.



THE OPERATOR'S MANUAL MUST BE READ AND UNDERSTOOD PRIOR TO OPERATING YOUR MEC SELF-PROPELLED SCISSORS. THE USER/OPERATOR SHOULD NOT ACCEPT OPERATING RESPONSIBILITY UNTIL HE/SHE HAS READ AND UNDERSTANDS THE OPERATOR'S MANUAL, UNDERSTANDS THEIR RESPONSIBILITIES SET FORTH IN THE ANSI MANUAL OF RESPONSIBILITIES PROVIDED WITH THIS LIFT, AS WELL AS HAVING OPERATED THE MEC SCISSOR LIFT UNDER SUPERVISION OF AN AUTHORIZED, TRAINED AND QUALIFIED OPERATOR.

MODIFICATIONS OF THIS MACHINE FROM THE ORIGINAL DESIGN AND SPECIFICATIONS WITHOUT WRITTEN PERMISSION FROM MEC ARE STRICTLY FORBIDDEN. A MODIFICATION MAY COMPROMISE THE SAFETY OF THE MACHINE, SUBJECTING OPERATOR(S) TO SERIOUS INJURY OR DEATH.

Your MEC Scissor Lift has been designed, built, and tested to provide safe, dependable service. Only authorized, trained and qualified personnel should be allowed to operate or service the machine.

MEC, As Manufacturer, Has No Direct Control Over Machine Application And Operation. Proper Safety Practices Are The Responsibility Of The User And All Operating Personnel.

If There Is A Question On Application And/Or Operation Contact:



MEC Aerial Platform Sales Corp

1775 Park Street, Suite 77. • Selma, CA 93662 USA
Ph: 1-800-387-4575 • 559-891-2488 • Fax: 559-891-2493
E-mail: info@mecawp.com • Web: www.mecawp.com



Machine Specifications

	1532ES	1932ES	2033ES	2633ES
Working Height	6.50 m	7.71 m	7.98 m	9.80 m
Platform Height	4.50 m	5.71 m	5.98 m	7.80 m
Stowed Height:	1.97 m	2.1 m	2.06 m	2.19 m
Folded Down Rails	NA	NA	1.86 m	1.94 m
Maximum Number of Occupants	2	2	2	2
Lift Capacity (Evenly Distributed):	272 kg	226 kg	363 kg	226 kg
Roll-out Deck Capacity	113 kg	113 kg	113 kg	113 kg
Platform Dimensions:				
With Roll-Out Deck extended	2.59 m		3.38 m	
With Roll-Out Deck Retracted	1.68 m		3.36 m	
Guard Rail Height	1.10 m		1.10 m	
Toe Board Height	19 cm		15 cm	
Roll-out Deck Length	0.91 m		1.0 m	
Overall Length	1.83 m		2.49 m	
Overall Width	0.81 m		0.84 m	
Wheel Base	1.27 m		1.80 m	
Wheel Track	0.70 m		0.70 m	
Turning Radius:				
Inside	5 cm		0 cm	
Outside	1.8 m		2.0 m	
Ground Clearance	7.6 cm		8.9 cm	
Machine Weight (Unloaded) (Approx.)	1225 kg	1375 kg	1737 kg	2105 kg
Drive System (Proportional):				
Drive Speed (Platform Elevated - Forward)	0 - 0.8 km/h		0 - 0.64 km/h	
Drive Speed (Platform Elevated - Reverse)	0 - 0.4 km/h		0 - 0.64 km/h	
Drive Speed (Platform Lowered)	0 - 3.7 km/h		0 - 2.7 km/h	
Lift/Lower Speed (Approx.)	14 sec / 28 sec		27 sec / 35 sec	
Gradeability	25% / 14°		24% / 13.5°	
Ground Pressure/Wheel (Maximum)	7.4 kg/cm ²	7.9 kg/cm ²	8.08 kg/cm ²	9.07 kg/cm ²
Wind Speed (Maximum)	0 m/s		0 m/s	
Tire Size-Standard (Solid, non-marking rubber)	35.56 cm x 11.43 cm		40.6 x 12.7 cm	
Wheel Lug Nut Torque	102 - 115 Nm		102 - 115 Nm	
Hydraulic Pressure:				
Main System	190 bar	190 bar	190 bar	190 bar
Lift System	131 bar	180 bar	166 bar	180 bar
Steer	62 bar	62 bar	62 bar	62 bar
Hydraulic Fluid Capacity	11.36 liters		11.36 liters	
Power System – Voltage	24 Volts DC		24 Volts DC	
Battery Charger				
Input	100-220 Volt AC, 50/60 Hz, 5.6 Amp		100-220 Volt AC, 50/60 Hz, 5.6 Amp	
Output	24 Volt DC, 25 Amps Tapering, Timed Shutoff		24 Volt DC, 25 Amps Tapering, Timed Shutoff	
Batteries	Four 6 Volt deep-cycle; 220 Amp hours @ 20 hour rating		Four 6 Volt deep-cycle; 220 Amp hours @ 20 hour rating	
Electric Motor	2.0 h.p. (1.49 kW); 3000 r.p.m.		2.0 h.p. (1.49 kW); 3000 r.p.m.	



Machine Specifications

	2047ES	2647ES	3247ES
Working Height	7.98 m	9.80 m	11.60 m
Platform Height	5.98 m	7.80 m	9.60 m
Stowed Height:	2.13 m	2.27 m	2.45 m
Folded Down Rails	1.65 m	1.81 m	1.97 m
Maximum Number of Occupants	0 m/s wind 12.5 m/s wind	3 N/A	2 N/A
Lift Capacity (Evenly Distributed):	567 kg	454 kg	318 kg
Roll-out Deck Capacity	113 kg	113 kg	113 kg
Platform Dimensions:			
With Roll-Out Deck Extended	3.39 m		
With Roll-Out Deck Retracted	2.31 m		
Guard Rail Height	1.10 m		
Toe Board Height	15.2 cm		
Roll-out Deck Length	1.07 m		
Overall Length	2.51 m		
Overall Width	1.19 m		
Wheel Base	1.80 m		
Wheel Track	1.04 m		
Turning Radius:			
Inside	0 cm		
Outside	2.4 m		
Ground Clearance	8.9 cm		
Machine Weight (Unloaded) (Approx.)	2019 kg	2404 kg	2717 kg
Drive System (Proportional):			
Drive Speed (Platform Elevated - Forward)	0 - 0.69 km/h		
Drive Speed (Platform Lowered)	0 - 4.0 km/h		
Lift/Lower Speed (Approx.)	34 sec / 35 sec	36 sec / 35 sec	42 sec / 45 sec
Gradeability	25%	25%	23%
Ground Pressure/Wheel (Maximum)	12.7 kg/cm ²	14.0 kg/cm ²	14.9 kg/cm ²
Wind Speed (Maximum)	12.5 m/s	0 m/s	0 m/s
Tire Size-Standard (Solid, non-marking rubber)	40.6 x 12.7 cm		
Wheel Lug Nut Torque	102 - 115 Nm		
Hydraulic Pressure:			
Main System	190 bar	207 bar	207 bar
Lift System	172 bar	172 bar	141 bar
Steer	76 bar	76 bar	76 bar
Hydraulic Fluid Capacity	17.0 liters		
Power System – Voltage	24 Volts DC		
Battery Charger			
Input	100-220 Volt AC, 50/60 Hz, 5.6 Amp		
Output	24 Volt DC, 25 Amps Tapering, Timed Shutoff		
Batteries	Four 6 Volt deep-cycle; 220 Amp hours @ 20 hour rating		
Electric Motor	2.0 h.p. (1.49 kW): 3000 r.p.m		



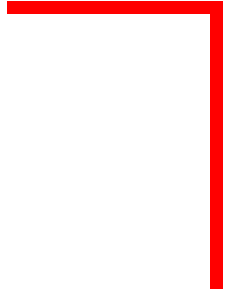

**SECTION 1:
SAFETY**



SAFETY SYMBOLS

This section of the manual contains important information of the safe use of your MEC Scissors. Failure to read, understand, and follow all safety rules, warnings, and instructions will unnecessarily expose you and others to dangerous situations. For your safety and the safety of those around you, you must operate your machine as instructed in this manual.

You, the operator, are the single most important factor for safety when using any piece of equipment. Learn to operate your machine in a safe manner.

To help you recognize important safety information, we have identified warnings and instructions that directly impact on safety with the following signals:



“DANGER” INDICATES AN IMMINENTLY HAZARDOUS SITUATION WHICH, IF NOT AVOIDED, WILL RESULT IN DEATH OR SERIOUS INJURY. THIS SIGNAL WORD IS LIMITED TO THE MOST EXTREME SITUATIONS.



“WARNING” INDICATES A POTENTIALLY HAZARDOUS SITUATION WHICH, IF NOT AVOIDED, COULD RESULT IN DEATH OR SERIOUS INJURY.



“CAUTION” indicates a potentially hazardous situation which, if not avoided, may result in minor or moderate injury. It may also be used to alert against unsafe practices. “CAUTION” is used for property-damage only accidents.

SAFETY RULES AND PRECAUTIONS

- ◆ MEC designs self-propelled scissor lifts to be safe and reliable. They are intended to position personnel, along with their necessary tools and materials to overhead work locations.
- ◆ The owner/user/operator of the machine should not accept responsibility for the operation of the machine, unless properly trained.



- ◆ **ELECTROCUTION HAZARD!!! THIS MACHINE IS NOT INSULATED!!**
- ◆ Maintain safe clearance from electrically charged conductors (power lines) and apparatus. You must allow for machine sway (side to side movement) when elevated and electrical line movement. This machine does not provide protection from contact with, or proximity to, an electrically charged conductor.
- ◆ You must maintain a CLEARANCE OF AT LEAST 3m between any part of the machine, or its load, and any electrical line or apparatus carrying over 300 volts up to 50,000 volts. 30cm additional clearance is required for every additional 30,000 volts.
- ◆ DEATH OR SERIOUS INJURY will result from contact with or inadequate clearance from any electrically charged conductor.
- ◆ Only authorized, trained and qualified personnel should operate the scissor lift.
- ◆ NEVER fasten fall protection lanyard to an adjacent structure while on the platform.
- ◆ Make sure that the platform entry is properly closed and secure before operating machine from the platform.
- ◆ NEVER exceed platform rated capacity. Review the section titled “Machine Specifications” (earlier in this manual) regarding model capacities and dimensions.



- ◆ Before operating the machine, read and understand all safety and control information found on the machine and in this manual.
- ◆ When operating the machine follow all safety and control information found on the machine and in this manual.
- ◆ Evenly distribute loads placed on the platform.
- ◆ NEVER use scaffolding, ladders or similar items to extend your reach while on the platform.
- ◆ NEVER climb down the beam assembly while the platform is raised.
- ◆ The “Moving the Machine” section (described later in this manual) requires that the brake be released. After performing this procedure, there is no means to stop the machine’s travel. MEC recommends using this procedure only in cases of emergency, and only for a short distance. Be on guard against machine runaway on sloping surfaces. Movement speed shall not exceed 8 km/h.
- ◆ NEVER attempt to open any hydraulic line or component without first relieving all system pressure.
- ◆ NEVER alter, modify, or disable any safety devices or interlocks.
- ◆ NEVER recharge the battery near sparks or open flames. Lead-acid batteries generate EXPLOSIVE HYDROGEN GAS. Always wear safety glasses.
- ◆ NEVER use the machine outdoors during electrical storms or in wind situations.
- ◆ Only raise the platform when the machine is on a firm, level surface.
- ◆ If the Tilt Alarm sounds, use extreme caution and lower the platform. Reposition machine on a firm, level surface before elevating again.
- ◆ SECURE all tools and other loose items to prevent injury to persons working on or below the platform.
- ◆ Precautions should be taken to prevent unauthorized personnel from operating the platform with the ground controls while the platform is in use.



- ◆ Before disengaging or disconnecting hydraulic motors with brake assembly from a towing vehicle, ensure that the machine cannot roll.
- ◆ Complete the “Prestart Inspection” at designated intervals.



- ◆ Use of scissor lift as a crane to lift oversized or hanging loads is prohibited.
- ◆ Always check route and areas are clear before driving, lifting or lowering.
- ◆ It is recommended to avoid sudden braking or steering. Go slowly and leave more maneuvering room during cold weather operation.

FALL PROTECTION NOTICE

The **Guardrail** System around the perimeter of the platform is the **fall protection system** for self-propelled elevating work platforms. It is **prohibited** to use an Aerial Work Platform manufactured by MEC with any portion, or all, of the guardrails **removed**.

Lanyard anchorage points on this type of equipment are not required. However, if anchorage points for lanyard attachments are required by site authorities or other regulations, the anchorage points on all equipment manufactured by MEC are recommended to be used for **work positioning restraints** of personnel only. Lanyard lengths are to be determined by operator/owner to restrict the operator to the confines within the **Guardrail** System.



**THE IMPROPER USE OF FALL ARREST SYSTEMS MAY
CAUSE MACHINE TO TIP RESULTING IN SERIOUS INJURY
OR DEATH.**



- ◆ NEVER operate this machine outdoors in windy conditions, except model 2047ES.
- ◆ ALWAYS observe the maximum wind speed of 0 m/s, except model 2047ES.
- ◆ Precautions should be taken when operating the machine outdoors. When elevated, pay attention to conditions especially when passing buildings or other large objects that may obscure windy conditions.
- ◆ NEVER modify or alter the machine without prior written permission from the manufacturer.
- ◆ NEVER replace components critical to machine stability with items of different weight or specification. See *Service and Parts Manual* for appropriate replacement part numbers.
- ◆ Do not use batteries that weigh less than original equipment. Each battery must weigh at least 27.3 kg.



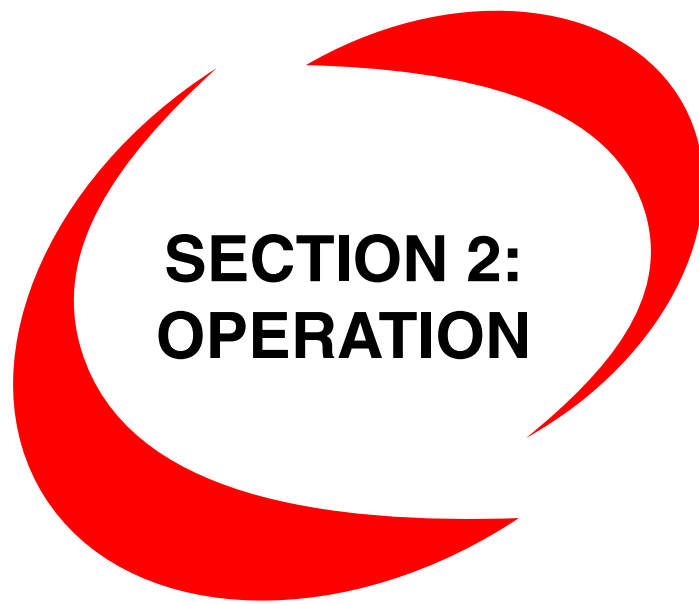
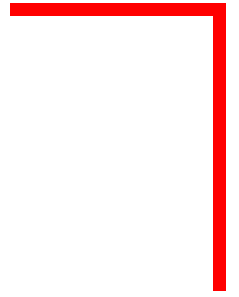

SECTION 2: OPERATION

TRANSPORT AND LIFTING INSTRUCTIONS



ONLY QUALIFIED RIGGERS SHOULD RIG AND LIFT THE MACHINE.

BE SURE THE CRANE CAPACITY, LOADING SURFACES AND STRAPS OR LINES ARE SUFFICIENT TO WITHSTAND THE MACHINE WEIGHT. SEE THE SERIAL PLATE FOR THE MACHINE WEIGHT.

Center of Gravity	X Axis	Y Axis
1532ES	61cm	46cm
1932ES	61cm	48cm
2033ES	86cm	50cm
2633ES	86cm	52cm
2047ES	90cm	52cm
2647ES	90cm	54cm
3247ES	90cm	60cm

LIFTING INSTRUCTIONS

- ◆ Fully lower the platform. Be sure the extension deck, controls and cabinet doors are secure. Remove all loose items on the machine.
- ◆ Determine the center of gravity of the machine using the table and picture on this page.
- ◆ Attach the rigging only to the designated lifting points on the machine. There are two holes on the front of the machine and two holes on the ladder for lifting.
- ◆ Adjust the rigging to prevent damage to the machine and to keep the machine level.

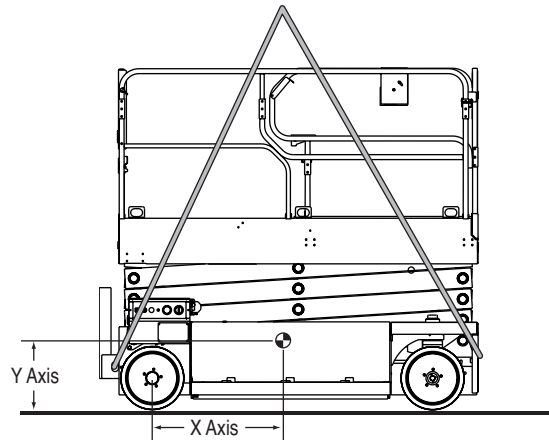

SECURING TO TRUCK OR TRAILER FOR TRANSPORT

- ◆ Always lock the extension deck in the retracted position when the machine is transported.
- ◆ Turn the key switch to the off position and remove the key before transport.
- ◆ Inspect the entire machine for loose or unsecured items.
- ◆ Use chains or straps of ample load capacity.
- ◆ Use a minimum of two chains or straps.
- ◆ Adjust the rigging to prevent damage to the chains and the machine.

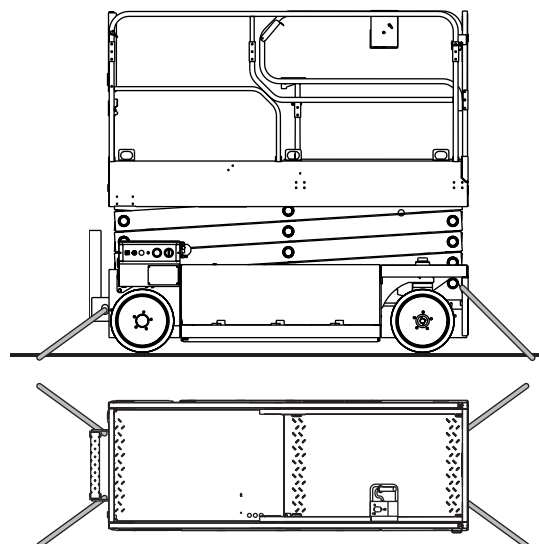

UNLOADING PROCEDURES

- ◆ Inspect the outside of the machine for damage. Inspect all hoses, beam assemblies (armset), and cables for chafing or road damage. Confirm that all wheel lug nuts are tight (refer to the “Machine Specifications”).
- ◆ Unlock and open side compartments. Inspect all electrical and hydraulic connections for damage and security.
- ◆ Turn battery switch to ON position. Check electrolyte level.
- ◆ Check engine oil level and add as required per engine manufacturer’s recommendations.
- ◆ Check that fluid level is to the fill mark on the hydraulic tank and add fluid as required (see “Lubrication Chart”).
- ◆ Close side compartments.



ALWAYS ATTACH THE MACHINE TO A WINCH WHEN LOADING OR UNLOADING FROM A TRUCK OR TRAILER IF DRIVEN OFF. WE DO NOT RECOMMEND UNASSISTED LOADING OR UNLOADING OF ANY SCISSOR LIFT.

READ AND UNDERSTAND ALL SAFETY, CONTROL, AND OPERATING INFORMATION FOUND ON MACHINE AND IN THIS MANUAL BEFORE OPERATING THE MACHINE.

- ◆ Attach the machine to a winch for the unloading.
- ◆ Perform Machine Start-up procedures in this section. Refer to Operator Controls Descriptions, as necessary.
- ◆ Remove all machine tie downs. Remove wheel chocks, if used. Turn the Base/ Platform selector switch to the “PLATFORM” position.
- ◆ Enter the platform, activate emergency stop switch (rotate clockwise and release). Test all platform functions.
- ◆ Carefully drive the machine off the truck or trailer with the winch still attached.

NOTE: The brakes are automatically released for driving and will automatically apply when the machine stops.

- ◆ **Before placing the machine into service, all operators must read and understand the contents of this Operator’s Manual.**

PRIMARY MACHINE COMPONENTS

Representative machine shown - all models similar.

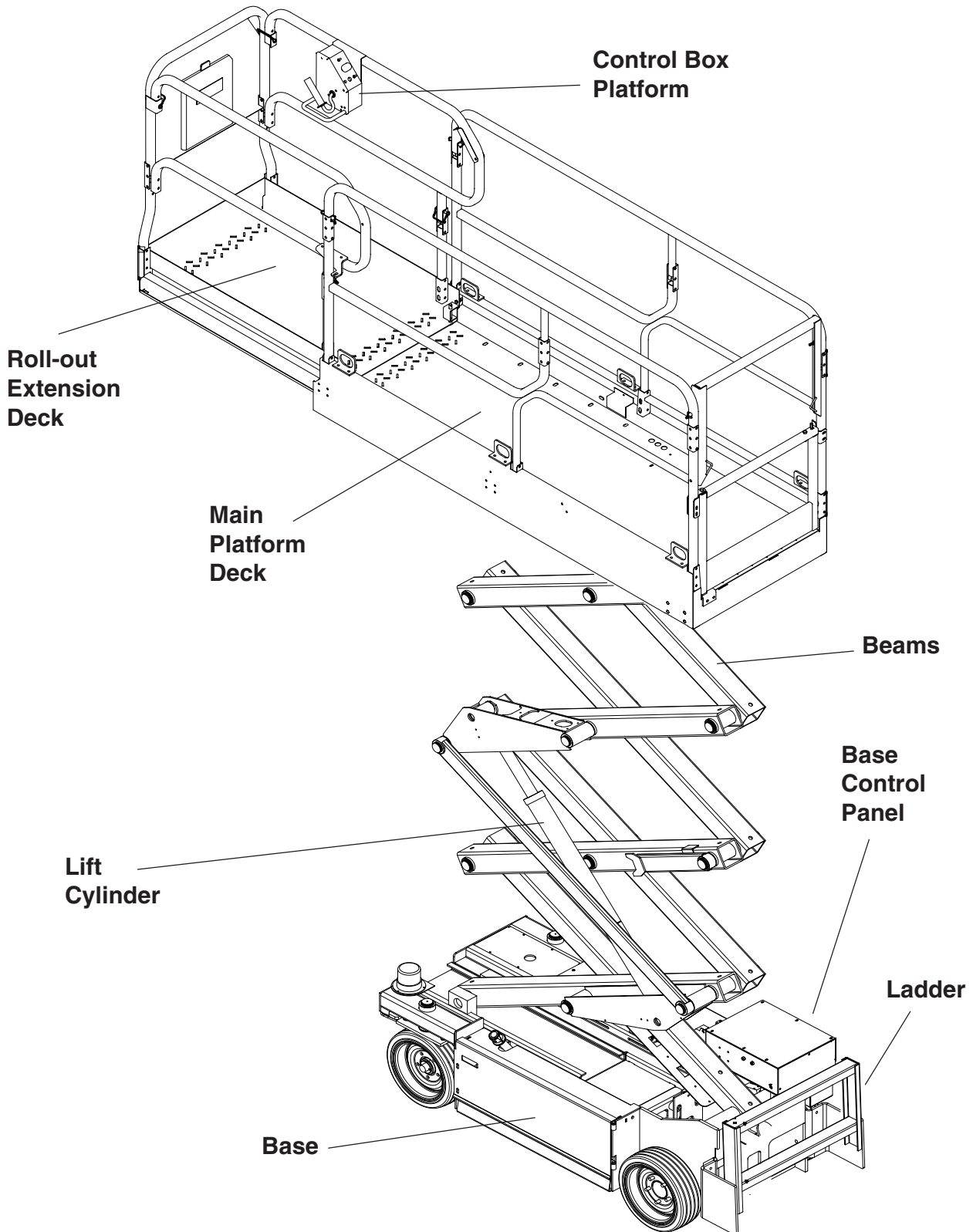

OPERATOR CONTROLS

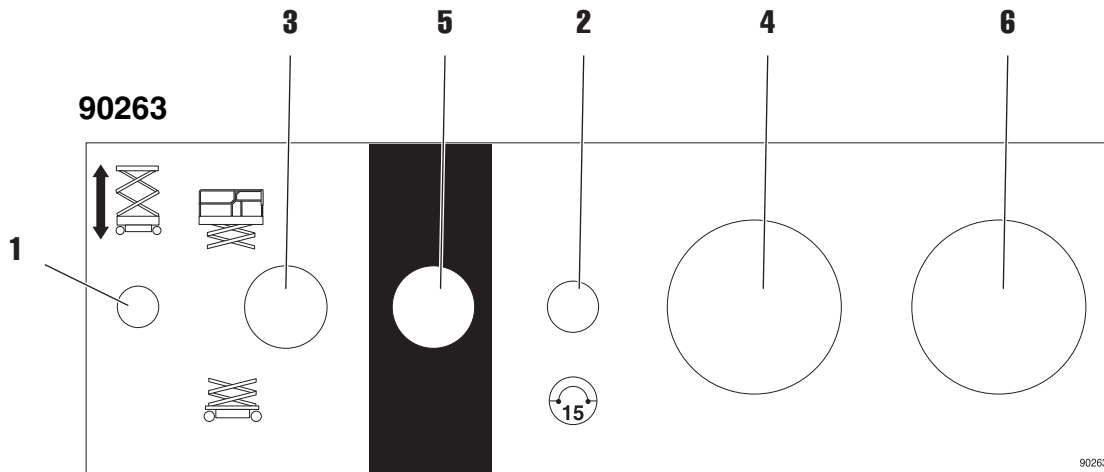

BASE CONTROLS

CONTROL		DESCRIPTION
1	Lift/Lower Switch	Use to control the lift and lowering of the platform from the base panel, when "BASE" position is selected as the primary control station.
2	Circuit-breaker	Pops out when there is excessive electrical load in the 12-volt control circuit. Push in to reset.
3	Base/Off/Platform Selector Switch	Select "BASE" position to control operation of machine using the base controls. Select "PLATFORM" position to control operation of machine using the platform console. NOTE: A key shall be provided for European machines and will be removable in "PLATFORM" position only.
4	Battery Gauge (Optional)	Indicates percent of charge left in batteries.
5	Emergency Stop Button	Use to stop all functions in an emergency. Push for emergency stop. To reset turn clockwise.
6	Hour Meter	Indicates total elapsed time the machine has been operated.

OPERATOR CONTROLS (Continued)



DANGER

YOU MUST NOT OPERATE THIS MACHINE:

UNLESS YOU HAVE BEEN AUTHORIZED TO USE AND TRAINED IN THE SAFE OPERATION OF THIS MACHINE.

TRAINING INCLUDES COMPLETE KNOWLEDGE OF THE SAFETY AND OPERATION INSTRUCTIONS CONTAINED IN THE MANUFACTURERS MANUAL, ANSI MANUAL OF RESPONSIBILITIES, YOUR EMPLOYERS WORK RULES AND APPLICABLE GOVERNMENTAL REGULATIONS.

AN UNAUTHORIZED AND UNTRAINED OPERATOR SUBJECTS THEMSELF AND OTHERS TO DEATH OR SERIOUS INJURY.



ELECTROCUTION HAZARD THIS MACHINE IS NOT INSULATED

MAINTAIN SAFE CLEARANCE FROM ELECTRICAL LINES AND APARATUS. YOU MUST ALLOW FOR MACHINE SWAY, ROCK OR SAG AND ELECTRICAL LINES SWAYING.

THIS MACHINE DOES NOT PROVIDE PROTECTION FROM CONTACT WITH OR PROXIMITY TO AN ELECTRICALLY CHARGED CONDUCTOR.

YOU MUST MAINTAIN A CLEARANCE OF AT LEAST TEN (10) FEET BETWEEN ANY PART OF THIS MACHINE OR ITS LOAD AND ANY ELECTRICAL LINE OR APARATUS CARRYING UP TO 50,000 VOLTS. ONE FOOT OF ADDITIONAL CLEARANCE IS REQUIRED FOR EVERY ADDITIONAL 30,000 VOLTS OR LESS.

**DEATH OR SERIOUS INJURY
WILL RESULT FROM CONTACT
OR INADEQUATE CLEARANCE**

TIP-OVER HAZARDS



**DO NOT DRIVE NEAR DROP-OFFS, HOLES
OPEN ELEVATOR SHAFTS, AND LOADING DOCKS**

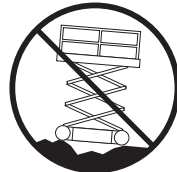

**DO NOT ELEVATE PLATFORM ON
UNEVEN OR SOFT SURFACES
DO NOT DRIVE ONTO UNEVEN OR
SOFT SURFACES WHEN ELEVATED**

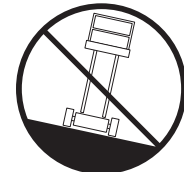
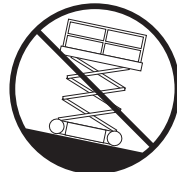

**DO NOT RAISE PLATFORM ON SLOPE, OR DRIVE
ONTO SLOPE WHEN ELEVATED**



**DO NOT RAISE PLATFORM IN
WINDY OR GUSTY CONDITIONS**

EXCEPT MODEL 2047

**DEATH OR SERIOUS INJURY
WILL RESULT FROM IMPROPER
USE OF THIS EQUIPMENT**



OPERATOR CONTROLS (continued)

PLATFORM CONTROLS

90901

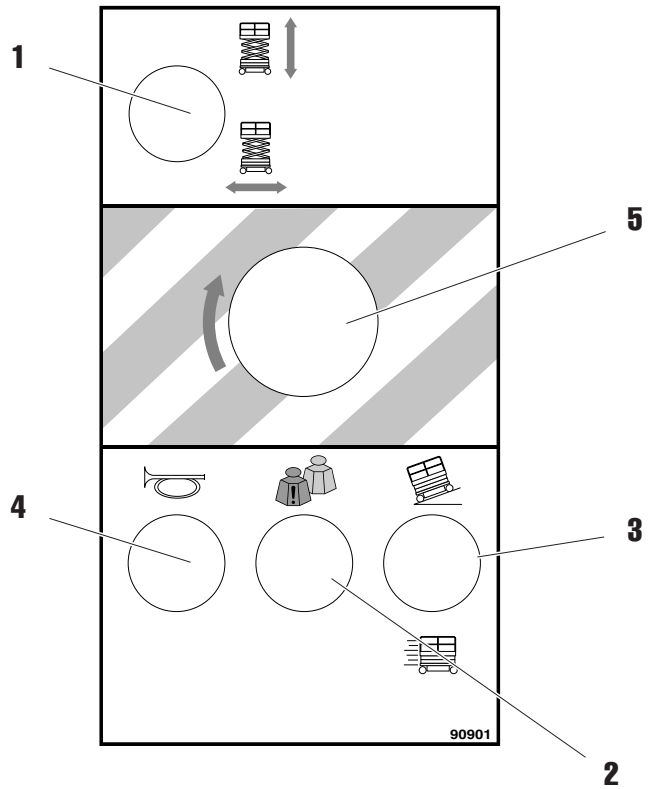

90729

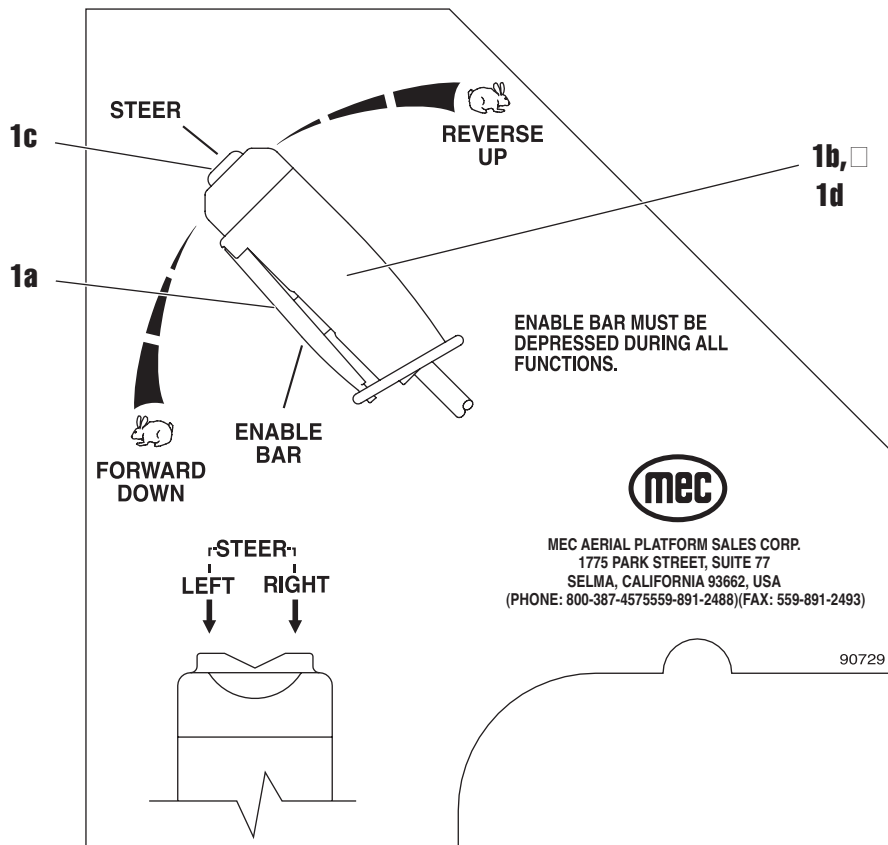

OPERATOR CONTROLS (continued)

PLATFORM CONTROLS

	CONTROL	DESCRIPTION
1	Mode Selector	Desired selection will allow either the lift or drive function using controller handle.
1a	Enable Bar	Must be depressed to active drive, steer, and lift functions.
1b	“Forward/Reverse”	Controls forward and reverse machine travel at speed proportional to handle movement.
1c	“Left/Right”	Push Steer Rocker Switch (thumb) to the left and hold to turn steer wheels to the left, right to turn steer wheels to the right.
1d	“Lift/Lower” Controller	With enable bar depressed, moving controller handle toward the operator (up) will provide platform lift at a speed proportional to handle movement. Moving the handle away from the operator (down) will provide platform lowering at a fixed speed.
2	Overload Warning Light	Indicates that platform is overloaded.
3	Torque On/Off Switch	“ON” selection will provide extra driving torque and reduce drive speed when the platform is under approximately 7 ft (2.13 m). “OFF” position is the normal mode.
4	Horn	Press button to sound warning horn.
5	Emergency Stop Button	Push to stop all functions in emergency. Reset by turning clockwise.



PRESTART INSPECTION

Before use each day or at the beginning of each shift, the machine shall be given a visual inspection and functional test. Repairs (if any) must be made prior to operating the machine as it is critical to ensure safe operation of the machine.

- ◆ Visually inspect all machine components; for loose or missing parts, hydraulic fluid leaks, loose or damaged wires. Check for structural or weld cracks.
- ◆ Check fluid levels with the platform fully lowered.
- ◆ Check the wheel lug nuts for tightness (Refer to “Machine Specifications”).
- ◆ Check that all warning and instructional labels are legible and secure.
- ◆ Check the platform guard rail system. Insure platform entry properly closes and secures.
- ◆ Ensure that emergency stop buttons on the base control panel and the platform controls are disengaged. Reset by turning clockwise.
- ◆ Ensure that the battery disconnect switch is in the “ON” position.

MACHINE START UP

1. Ensure the battery disconnect switch, located on Base Control Box, is in the “ON” position.
2. Place the base/platform select switch to the desired position.
3. The machine can now be operated from the selected position.

NOTE: If the machine fails to operate, inspect the motor controller inside the motor compartment. A green LED located on the controller should be illuminated. If the LED is not illuminated, refer to the troubleshooting section.

BASE CONTROL OPERATION AND CHECKS



◆ **ELECTROCUTION HAZARD!!! THIS MACHINE IS NOT INSULATED!!**

Maintain safe clearance from electrically charged conductors (power lines) and apparatus. You must allow for machine sway (side to side movement) when elevated and electrical line movement. This machine does not provide protection from contact with, or proximity to, an electrically charged conductor.



BE SURE AREA ABOVE THE MACHINE IS CLEAR OF OBSTRUCTIONS TO ALLOW FULL ELEVATION OF PLATFORM.

DO NOT OPERATE THE MACHINE IF THE FOLLOWING CHECKS REVEAL A DEFECT.

- ◆ Turn selector switch to “BASE” position.
- ◆ Activate the Lift/ Lower switch on the base control panel to elevate the platform to the end of its movement. Releasing the switch should stop elevation.
- ◆ Test the “Emergency Stop” function. While the platform is moving, press the Emergency Stop button, platform should stop.
- ◆ Reset by rotating clockwise.
- ◆ Lower the platform about halfway by switching the Lift/ Lower switch. Releasing the switch should stop the lowering.
- ◆ Check for proper operation and hydraulic leaks. Rotate the maintenance lock into position before inspecting any items inside or around scissor arms.
- ◆ Rotate the maintenance lock into position. Lower platform to the stowed position.
- ◆ At approximately 2.5 meter platform height the automatic armguard cutout will stop the platform. Verify that there are no hazardous conditions and that no other persons are touching the machine. After a five second delay lowering can resume.

PLATFORM CONTROL OPERATION AND CHECKS

- ◆ Select the “Platform” position on the selector switch at base control station.
- ◆ Enter platform and close and secure the entry.
- ◆ Press the horn button briefly to check if working properly, if installed.

IMPORTANT: The Enable Bar must be activated to operate the controller for Drive, Steer, and Lift/ Lower Function.

- ◆ Check for proper operation and hydraulic fluid leaks.
- ◆ Move mode selector switch to “Lift” position, depress Enable bar and move control handle “up” (toward the operator).
- ◆ Test emergency stop function by pressing down on the red Emergency Stop switch. Reset by rotating clockwise.
- ◆ To lower platform, depress the Enable bar and move control handle “down” (away from the operator).
- ◆ At approximately 2.5 meter platform height the automatic armguard cutout will stop the platform. Verify that there are no hazardous conditions and that no other persons are touching the machine. After a five second delay lowering can resume.



IF PLATFORM SHOULD FAIL TO LOWER DO NOT ATTEMPT TO CLIMB DOWN THE BEAM ASSEMBLY. SERIOUS INJURY MAY RESULT.

IMPORTANT: Always check front steer wheel direction before driving.

- ◆ Move mode select switch to “Drive” position. Test Left/ Right steering by depressing Enable bar on control handle and pressing the rocker switch at the top of the handle. Press left side of switch for left steer direction and right side for right steer direction.
- ◆ Move the mode select switch to “Drive” position, depress Enable bar and move control handle “forward” and “backward” to check drive direction. Releasing the Enable bar or returning control handle to center position will stop motion of drive.
- ◆ Test the “Emergency Stop” function. While driving in both directions. Reset “Emergency Stop” by rotating the switch clockwise.

OPERATION



**THE OPERATOR MUST BE AWARE OF THE ENVIRONMENT.
DO NOT RAISE THE PLATFORM IF THE MACHINE IS NOT ON A
FIRM LEVEL SURFACE.**

**SAFE OPERATION BEGINS WITH A SAFETY CONSCIOUS
EQUIPMENT OPERATOR.**

Perform prestart inspection. Remember to place the selector switch in the “Platform” position before getting in the platform for operation.

DRIVING AND STEERING



**CHECK THAT THE ROUTE OF TRAVEL TO BE TAKEN IS
CLEAR OF PERSONS, OBSTRUCTIONS, DEBRIS, HOLES, AND
DROP OFFS, AND IS CAPABLE OF SUPPORTING THE
MACHINE.**

NOTE: To activate drive function, activate mode selector switch in “Drive” position. Depressing the Enable bar, drive and steer functions can be achieved. Steer wheels will not center themselves after a turn, and must be returned to the straight-ahead position with the steer switch.

Controller handle movement “away” from the operator will give FORWARD travel and pulling the handle “towards” the operator will give REVERSE travel.

Travel speed is proportional and is controlled by the movement of the controller handle. The further it is moved the faster the speed will be. The controller handle returns to neutral (center) position when released.

PLATFORM OVERLOAD SENSING SYSTEM

A flashing red indicator light on the upper control box indicates that the platform is overloaded. An alarm at both the platform and the base will sound and all functions will be prevented. Remove weight from platform until system resets and the alarm and light go off. Normal function will then be restored.

BRAKING



ACTIVATION OF THE PLATFORM “EMERGENCY STOP” BUTTON WILL APPLY BRAKES IMMEDIATELY. THIS MAY CAUSE UNEXPECTED PLATFORM MOVEMENT AS THE MACHINE COMES TO A SUDDEN STOP. BRACE YOURSELF AND SECURE OBJECTS ON THE PLATFORM DURING OPERATION OF MACHINE.

NOTE: For parking, the brake is automatically applied when the forward/reverse drive controller is positioned in the center (neutral) position.

ELEVATING THE PLATFORM

USING PLATFORM CONTROLS

To elevate the platform, activate mode selector switch in the “Lift” position. Depressing the Enable bar and moving controller handle “towards” the operator will elevate the platform. Rate of lift is proportional and is dependent on the movement of the controller handle.

USING BASE CONTROLS

With selector switch in the “Base” position, press and hold the Lift/ Lower toggle switch on the base control panel in the “Up” position until the desired height is reached or until the platform reaches maximum height.

LOWERING THE PLATFORM

USING PLATFORM CONTROLS

To lower the platform, activate mode selector switch to the “Lift” position. Depressing the Enable bar and moving the controller handle “away” from the operator will lower the platform. Rate of descent is fixed - platform lowers at same rate regardless of handle position.

USING BASE CONTROLS

With selector switch in the “Base” position, press and hold the Lift/ Lower toggle switch in the “Down” position until the desired platform height is reached or until the platform reaches the stowed position.

EXTENDING THE ROLL-OUT EXTENSION DECK

- ◆ Lift handle at the rear of the extension deck to raise spring-loaded pin from the locked position.
- ◆ With handle raised, push the deck out to the desired extended length and release the handles for the spring-loaded pin to lock into position.
- ◆ Extensions can be achieved in intervals of 6 inches (15 cm) throughout the entire length of the roll-out extension deck.



IF THE ROLL-OUT DECK IS EXTENDED CHECK FOR CLEARANCE UNDER DECK AREA BEFORE LOWERING PLATFORM.

CHARGING THE BATTERIES



LEAD-ACID BATTERIES GENERATE EXPLOSIVE GASES. KEEP SPARKS AND FLAME AWAY FROM BATTERIES.

NO SMOKING !

- ◆ Plug the battery charger into 100-220 volt, 50/60 Hz AC outlet, using #12 AWG grounded extension cord to recharge the batteries.

To determine if the batteries are fully charged, plug the charger in. The LED indicating 2/3 charge illumination within a few minutes indicates that the batteries are fully charged.



DO NOT OPERATE THE UNIT WHILE CHARGING.

BE SURE TO DISCONNECT THE CHARGER FROM THE OUTLET BEFORE MOVING THE UNIT.

SHUTDOWN PROCEDURE

- ◆ When finished with the machine, place the platform in the stowed position.
- ◆ Park the machine on a level surface.
- ◆ Carefully exit the platform using a constant three (3) point dismount/grip.
- ◆ Place selector switch at base control panel in the “Off” position.

NOTE: Leaving the selector switch in the base or platform position for an extended time will drain the battery. Always put the selector switch in “Off” position when leaving the machine at the end of the work day.

- ◆ Put a padlock on the battery disconnect switch to prevent unauthorized operation.

MOVING THE MACHINE

Machine can be winched or moved short distances in case of power failure at speeds not to exceed 5 MPH (8.05 kph).

TOWING/ WINCHING THE MACHINE

Your machine is equipped with a brake release.



PRIOR TO MANUALLY RELEASING BRAKES, INSURE WHEELS ARE CHOCKED TO PREVENT MACHINE FROM MOVING.

Release Brakes Before Towing:

- ◆ Push in the manual brake release valve located on the main manifold.
- ◆ Using the hand pump in the battery compartment, pump valve until pressure is built.
- ◆ Machine is now ready for towing.

MOVING THE MACHINE (continued)

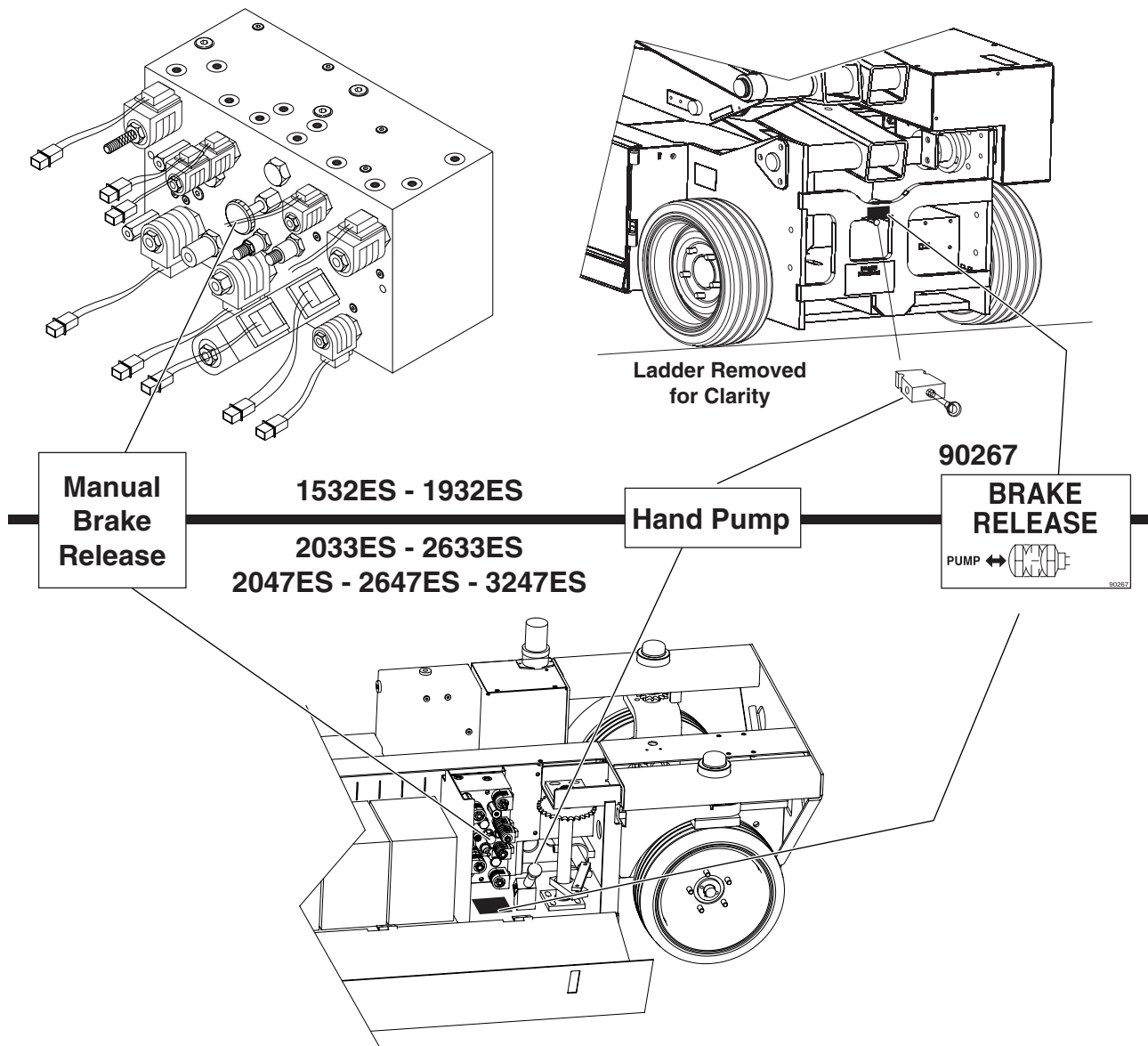

AFTER RELEASING THE BRAKES, THERE IS NOTHING TO STOP THE MACHINE'S TRAVEL. MACHINE WILL ROLL FREELY ON SLOPES. BE ON GUARD AGAINST RUNAWAY. DO NOT DRIVE MACHINE WITH BRAKES RELEASED.

To Reset Brakes:

- ◆ Brakes will reset when drive function is activated or reset by pulling on manual brake release valve.

EMERGENCY SYSTEMS AND PROCEDURES



IF THE CONTROL SYSTEM FAILS WHILE THE PLATFORM IS ELEVATED, HAVE AN EXPERIENCED OPERATOR USE THE EMERGENCY LOWERING PROCEDURE TO SAFELY LOWER THE PLATFORM.

NEVER CLIMB DOWN BEAM ASSEMBLY WHEN PLATFORM IS RAISED.



BEFORE LOWERING PLATFORM RETRACT THE DECK EXTENSION.

EMERGENCY LOWERING - 1532ES, 1932ES, 2033ES, 2633ES, 2047ES, AND 2647ES MODELS

The Emergency Down System is used to lower the platform in case of power or valve failure. To lower the platform, perform the following steps:

1. Pull and turn knurled knob on lift cylinder counterclockwise to lock the valve in open position.
2. Pull manual activator (override valve) on main manifold to lower platform to desired height.
3. To return to normal operation, turn knurled knob on lift cylinder clockwise. Valve will automatically lock.

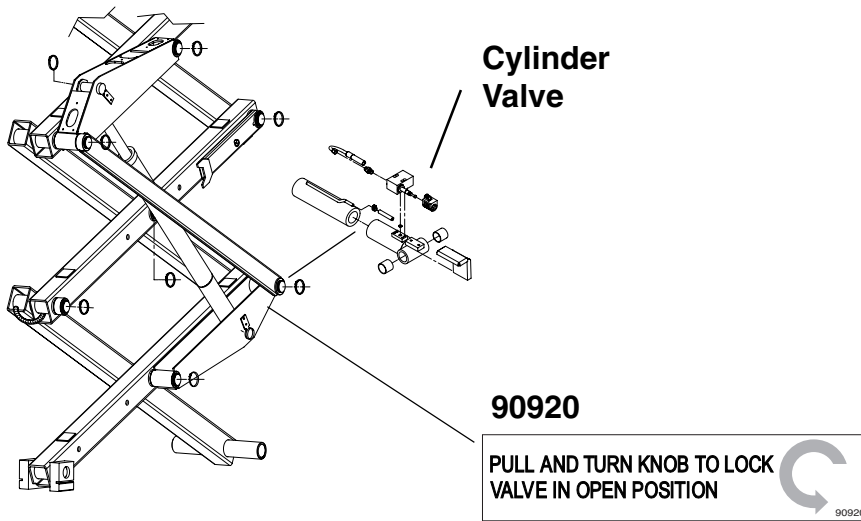

Manual Activator

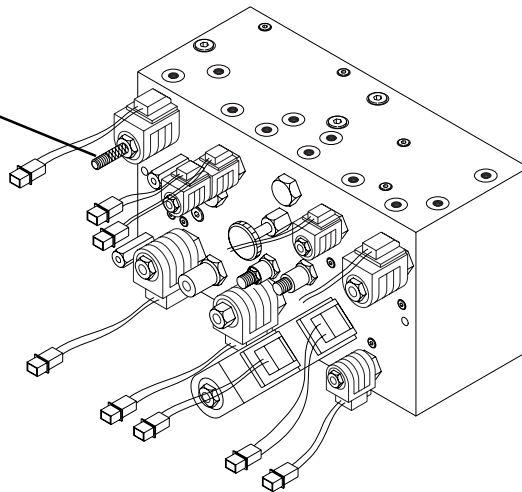

EMERGENCY LOWERING - 3247ES

The Emergency Down System is used to lower the platform in case of power or valve failure. To lower the platform, perform the following steps:

1. Push down on the toggle switch and hold it to lower the platform to the desired height.
2. Once the platform is fully lowered, release the toggle switch to close the valve.

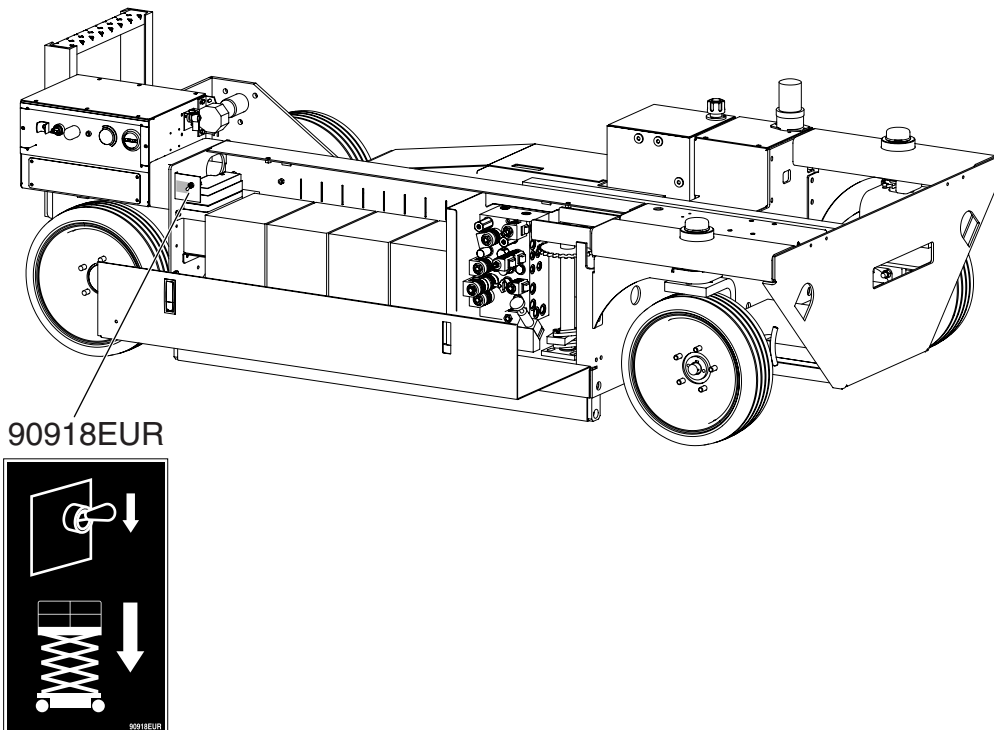



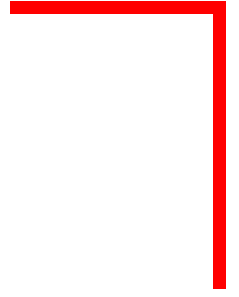

**SECTION 3:
MAINTENANCE**

GENERAL MAINTENANCE TIPS

Regular inspection and conscientious maintenance is the key to efficient economical operation of your scissor lift. It will help to assure that your equipment will perform satisfactorily with a minimum of service and repair.

The actual operating environment of the machine governs the inspection schedule. Correct lubrication is an essential part of the preventative maintenance to minimize wear on working parts and ensure against premature failure. By maintaining correct lubrication, the possibility of mechanical failure and resulting downtime is reduced to a minimum.



NEVER PERFORM SERVICE ON THE MACHINE (WITH THE PLATFORM ELEVATED) WITHOUT FIRST BLOCKING THE BEAMS (SCISSORS) ASSEMBLY IN PLACE USING THE MAINTENANCE LOCK!

- ◆ Block scissors assembly using maintenance lock if machine is in the elevated/extended position.
- ◆ Never leave hydraulic components or hoses open. They must be protected from contamination (including rain) at all times.
- ◆ Never open a hydraulic system when there are contaminants in the air.
- ◆ Always clean the surrounding area before opening hydraulic systems.
- ◆ Use only recommended lubricants. Improper lubricants or incompatible lubricants may be as harmful as no lubrication.
- ◆ Watch for makeshift “fixes” which can jeopardize safety as well as lead to more costly repair.

GENERAL MAINTENANCE TIPS (Continued).....



HYDRAULIC FLUID UNDER PRESSURE CAN PENETRATE AND BURN SKIN, DAMAGE EYES, AND MAY CAUSE SERIOUS INJURY, BLINDNESS, AND EVEN DEATH. CORRECT LEAKS IMMEDIATELY.



Failure to perform preventive maintenance at recommended intervals may result in the unit being operated with a defect that could result in injury or death of the operator.

Immediately report to your supervisor any Defect or malfunction. Any defect shall be repaired prior to continued use of the scissor lift.

Inspection and maintenance should be performed by qualified personnel familiar with the equipment.

Fluid leaks under pressure may not always be visible. Check for pin hole leaks with a piece of cardboard, not your hand.

PRESTART INSPECTION



THIS INSPECTION MUST BE COMPLETED BEFORE MACHINE USE EACH DAY OR AT THE BEGINNING OF EACH SHIFT. FAILURE TO DO SO COULD RESULT IN DEATH OR SERIOUS INJURY.

- ◆ User/Operator is responsible for the Pre-Start Inspection.
- ◆ Keep inspection records up-to-date.
- ◆ Record and report all discrepancies to your supervisor.

MODEL NUMBER _____ **SERIAL NUMBER** _____

INITIAL

DESCRIPTION

- | | |
|-------|---|
| _____ | 1. Perform a visual inspection of all machine components, i.e. missing parts, torn or loose hoses, hydraulic fluid leaks, torn or disconnected wires, damaged tires etc. Replace components as necessary. |
| _____ | 2. Check the hydraulic fluid level with the platform fully lowered. |
| _____ | 3. Check the tires for damage. Check wheel lug nuts for tightness. |
| _____ | 4. Check the hoses and the cables for worn areas or chafing. Replace if necessary. |
| _____ | 5. Check the platform rails and safety gate for damage. |
| _____ | 6. Check the pivot pins for security. |
| _____ | 7. Check that all warning and instructional labels are legible and secure. |
| _____ | 8. Inspect the platform control. Ensure the load capacity is clearly marked. |
| _____ | 9. Check the hydraulic system pressure (See Machine Specification). If the pressure is low, determine the reason and repair in accordance with accepted procedures as outlined in the service manual. |



PRESTART INSPECTION (Continued).....

INITIAL

DESCRIPTION

10. Check the base controls for proper operation. Check all switches and push buttons for proper operation.

11. Check the platform controls for proper operation. Check all switches and push buttons, as well as ensuring that the drive controller returns to neutral.

DATE _____ INSPECTED BY _____

FREQUENT INSPECTION



THIS INSPECTION MUST BE COMPLETED EVERY 3 MONTHS OF SERVICE OR 150 HOURS, WHICHEVER OCCURS FIRST, OR IF A MACHINE HAS BEEN OUT OF SERVICE FOR GREATER THAN 3 MONTHS. FAILURE TO DO SO COULD RESULT IN DEATH OR SERIOUS INJURY.

- ◆ Owner/User is responsible for Frequent Inspections.
- ◆ The inspection must be performed by a person(s) qualified as a mechanic on this specific make and model of aerial work platform.
- ◆ Keep inspection records up-to-date.
- ◆ Record and report all discrepancies to your supervisor.

MODEL NUMBER _____ **SERIAL NUMBER** _____

INITIAL

DESCRIPTION

- | | |
|-------|--|
| _____ | 1. Perform all checks listed on Prestart Inspection. |
| _____ | 2. Inspect the condition of hydraulic fluid in the reservoir. Oil should have a clear amber color. |
| _____ | 3. Inspect the entire machine for signs of damage, broken welds, loose bolts, improper or makeshift repairs. |
| _____ | 4. Check the pin joints and retaining rings for security. |
| _____ | 5. Check if tires are leaning in or out. |
| _____ | 6. Check that all adjustable flow valves are locked, check setting if any are not locked. |
| _____ | 7. Check that the platform does not drift down with a full load. |
| _____ | 8. Check the electrical motor brushes. |

DATE _____ **INSPECTED BY** _____



ANNUAL INSPECTION



THIS INSPECTION MUST BE COMPLETED NO LATER THAN 13 MONTHS FROM THE DATE OF THE PRIOR ANNUAL INSPECTION. FAILURE TO ACCOMPLISH THIS INSPECTION COULD RESULT IN DEATH OR SERIOUS INJURY.

MODEL NUMBER _____ SERIAL NUMBER _____

- ◆ Owner/User is responsible for Annual Inspections.
- ◆ The inspection must be performed by a person(s) qualified as a mechanic on this specific make and model of aerial work platform.
- ◆ Keep inspection records up-to-date.
- ◆ Record and report all discrepancies to your supervisor.

ANNUAL INSPECTION TO BE PERFORMED IN ACCORDANCE WITH THE ANNUAL INSPECTION REPORT SHOWN ON THE FOLLOWING PAGE

Annual Inspection Report



Aerial Platform Sales Corp.

1775 Park Street, Suite 77 • Selma, CA 93662 USA
800-387-4575 • 559-891-2488 • Fax: 559-891-2493

Date	_____
Serial Number	_____
Model Number	_____
Date Of Last Inspection	_____
Date Placed In Service	_____

Customer	_____
Street	_____
City/State/Zip	_____
Phone Number	_____
Contact	_____

Dealer	_____
Street	_____
City/State/Zip	_____
Phone Number	_____
Contact	_____

- Check each item listed below.
- Use proper Operating, Service, and Maintenance manual for specific information and settings.
- If an item is found to be "Unacceptable" make the necessary repairs and check the "Repaired" box.
- When all items are "Acceptable", the unit is ready for service.

Key: "Y" Yes/Acceptable
"N" No/Unacceptable
"R" Repaired
"U" Unnecessary/Not Applicable

	Y	N	R	U		Y	N	R	U		Y	N	R	U
Decals:					Base:					Operation:				
Proper Placement/Quantity					Cover Panels Secure					Wires Tight				
Legibility					Base Fasteners Tight					Switches Secure				
Correct Capacity Noted					Bolts Tight					All Functions Operational				
Rails:					Front Axle Mounting (4WD)					Emergency Down:				
All Rail Fasteners Secure					Rear Axle Mounting (4WD)					Operational				
Entry Gate/Chain Closes Properly					Front Axle/Front Wheel Assemblies:					Slow Speed Limit Switch:				
Manual/Safety Data In Box					Wheel Motors-Mounting Secure					Set Properly				
Rear Rail Pad In Place					Wheel Motors-Leaks					Pothole Bars:				
Extending Platform:					Lug Nuts Torqued Properly					Operate Smoothly				
Slides Freely					Steering Cylinder Pins Secure					Lock In Place				
Latches In Stowed Position					Pivot Points Lubed					Limit Switches Adjusted				
Latches In Extended Position					Drive Assembly Front Hubs:					Pressures & Hydraulics:				
Rail Latches Work Properly					Castle Nut Torqued Properly					Oil Filter Secure/Chg				
Cable Secure					Cotter Pinned					Oil Level Correct/Chg				
Platform:					Rear Axle/Rear Wheel Assemblies:					Steering Pressure Set				
Platform Bolts Tight					Brakes Operational					Drive Pressure Set				
Platform Structure					Wheel Motors-Mounting Secure					Lift Pressure Set				
Platform Overload System:					Wheel Motors-Leaks					Engine:				
Functional					Lug Nuts Torqued Properly					Engine Mounts Tight				
Calibrated					Axle Pivot Lubed (4WD)					Fuel Lines Secure				
Wire Harnesses:					Axle Lock Operational					Fuel Lines Free Of Leaks				
Mounted Correctly					Component Area:					Fuel Tanks Secure				
Physical Appearance					Valve Manifold(s) Secure					Fuel Shut Off Valves Func.				
110/220V Outlet Safe/Working					Hoses Tight/No Leaks					All Shields/Guards In Place				
Scissors:					D/C Mtr(s) Secure/Operational					Oil Level				
Beam Structures					Contactors Secure					Oil Filter				
Welds					Pump Secure					Air Filter				
Retaining Rings					Batteries:					Options Operational:				
Upper Cylinder Pins Secure					Secure					Hour Meter				
Lower Cylinder Pins Secure					Fully Charged					Battery Indicator				
Lower Beam Mounts tight					Battery Charger:					Warning Light				
Rollers Turn Freely					Secure					Warning Horn				
Maintenance Locks:					Operational					Generator				
Secure					Emergency Stop:					Converter				
Operational					Breaks All Circuits									

Comments: _____

Signature/Mechanic: _____ Date: _____
 Signature/Owner-User: _____ Date: _____



TROUBLESHOOTING



SHOULD YOU EXPERIENCE ERRATIC OPERATION OR NOTICE ANY MALFUNCTION WHILE OPERATING THIS MACHINE, DISCONTINUE USE IMMEDIATELY.

CALL FOR ASSISTANCE AND REPORT THE INCIDENT TO YOUR SUPERVISOR, AND DO NOT USE THE MACHINE UNTIL IT HAS BEEN CHECKED BY A TRAINED, QUALIFIED MECHANIC.

WHAT TO CHECK IF FUNCTIONS WILL NOT OPERATE:

- ◆ Battery cutoff switch?
- ◆ Is a function toggle switch or the enable switch not activated?
- ◆ Is the Base/Off/Platform switch in the proper position?
- ◆ Batteries fully charged?
- ◆ Check emergency stop buttons at both base and platform?
- ◆ Hydraulic fluid level low?
- ◆ Obvious fluid leak or damaged component?
- ◆ Are any wires pulled out or loose?

LUBRICATION DIAGRAM

Hydraulic Lubrication

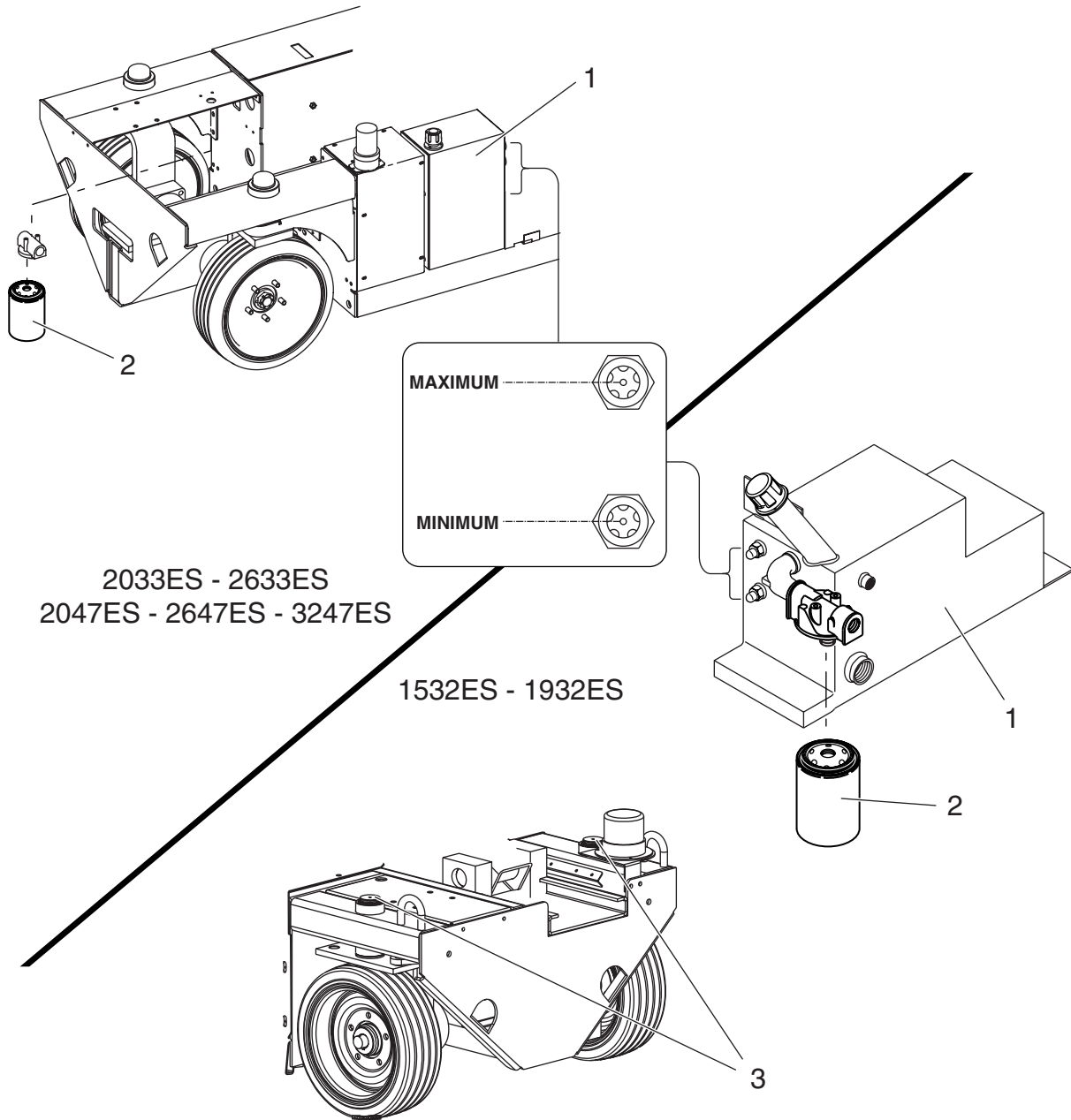

LUBRICATION CHART

NO.	ITEM	SPECIFICATION	FREQUENCY OF LUBRICATION
1	Hydraulic Reservoir	Anti-Wear 150 SSU (ISO 32/mil spec 0-5606) Fill to the top Sight Gauge with platform in the stowed position. <i>DO NOT</i> operate with the level below MINIMUM.	Check daily. Analyze every six (6) months or 500 hours. Change yearly or every 1,000 hours, whichever occurs first.
2	Hydraulic Filter	Filter Element	Change every six (6) months or 500 hours, whichever occurs first for normal usage. Change every three (3) months or 300 hours, whichever occurs first for severe usage.
3	Wheel Motor Mount	Lithium N.L.G. #2 EP Purge Old Grease 1532ES / 1932ES ONLY	Weekly or every 25 hours, whichever occurs first.



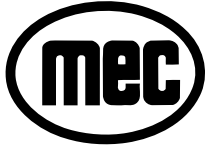

Limited Owner Warranty

MEC Aerial Platform Sales Corp. warrants its equipment to the original purchaser against defects in material and/or workmanship under normal use and service for one (1) year from date of registered sale or date the unit left the factory if not registered. MEC Aerial Platform Sales Corp. further warrants the structural weldments of the main frame and scissor arms to be free from defects in material or workmanship for five (5) years from date of registered sale or date unit left the factory if not registered. Excluded from such warranty is the battery(s) which carries a ninety (90) day warranty from described purchase date. Warranty claims within such warranty period shall be limited to repair or replacement, MEC Aerial Platform Sales Corp's option, of the defective part in question and labor to perform the necessary repair or replacement based on MEC Aerial Platform Sales Corp's then current flat rate, provided the defective part in question is shipped prepaid to MEC Aerial Platform Sales Corp. and is found upon inspection by MEC Aerial Platform Sales Corp. to be defective in material and/or workmanship. MEC Aerial Platform Sales Corp. shall not be liable for any consequential, incidental or contingent damages whatsoever. Use of other than factory authorized parts; misuse, improper maintenance, or modification of the equipment voids this warranty. The foregoing warranty is exclusive and in lieu of all other warranties, express or implied. All such other warranties, including implied warranties of merchantability and of fitness for a particular purpose, are hereby excluded. No Dealer, Sales Representative, or other person purporting to act on behalf of MEC Aerial Platform Sales Corp. is authorized to alter the terms of this warranty, or in any manner assume on behalf of MEC Aerial Platform Sales Corp. any liability or obligation which exceeds MEC Aerial Platform Sales Corp's obligations under this warranty.



Aerial Platform Sales Corp.

1775 Park Street, Suite 77. • Selma, CA 93662 USA

Ph: 1-800-387-4575 • 559-891-2488 • Fax: 559-891-2493

www.mecawp.com